

# "EUROMODEL" FIXED LEVER WITH SMOOTH BORED INSERT

# A151



**PROTECTED MODEL**

**Material:**

Special high resistance glass fiber reinforced technopolymer.  
Oils and greases resistant.

**Surface:**

Satin.

**Colour:**

Black (RAL 9011).

**Central Cap:**

grey polyamide (RAL 7035).

**Main Insert:**

Zinc plated steel insert, with right through smooth bore (bore tolerance H10).



**Alternative cap colours**

- Orange (RAL 2004 cod. 02)
- Blue (RAL 5015 cod. 07)
- Yellow (RAL 1021 cod. 10)
- Red (RAL 3000 cod. 16)
- Green (RAL 6024 cod. 17)
- Black (RAL 9011 cod. 01)

**SPECIAL REQUESTS:**

- Fixing springs and balls (zinc plated steel) available upon request.
- It's possible to supply the inserts with d1 diameter by customer design, on request and for quantities.
- It's possible to supply the inserts with different materials, on request and for quantities.
- It's possible to supply the inserts with different treatment, on request and for quantities.
- It's possible to supply the lever body and cap with colours as shown in the table at page A-31 on request and for quantities.

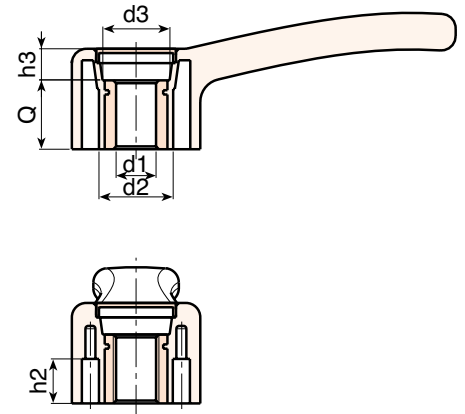
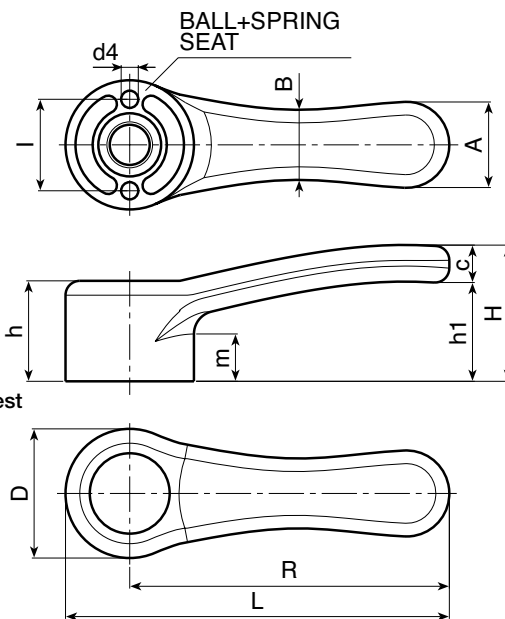

Art.	L	R	D	H	h	h1	h2	h3	m	l	A	B	c	d2	d3	d4	dm	d1 H10	Q	g
● <b>A151068.TD0501</b>	84,5	68	33	37	25	27	11,5	9	12	24	20	17	10	20	16	4	10	05	16	45
● <b>A151068.TD1001</b>	84,5	68	33	37	25	27	11,5	9	12	24	20	17	10	20	16	4	10	10	16	44
● <b>A151086.TD0501</b>	104	86	36	40	28	29	14	12	13	26	24	19	11	22	18	5	12	05	16	65
● <b>A151086.TD0801</b>	104	86	36	40	28	29	14	12	13	26	24	19	11	22	18	5	12	08	16	63
● <b>A151086.TD1001</b>	104	86	36	40	28	29	14	12	13	26	24	19	11	22	18	5	12	10	16	61
● <b>A151086.TD1201</b>	104	86	36	40	28	29	14	12	13	26	24	19	11	22	18	5	12	12	16	59
● <b>A151112.TD0501</b>	134,5	112	45	47	36	35	14,5	12	16	32	30	24	13	26	23,5	6	16	05	24	128
● <b>A151112.TD1201</b>	134,5	112	45	47	36	35	14,5	12	16	32	30	24	13	26	23,5	6	16	12	24	124
● <b>A151142.TD0501</b>	169,5	142	55	52	40	36	18	13	17,5	40	37	30	16	32	28	8	20	05	27	250

**Attention:** bore d1 (H10 tolerance) could be produced by request, with 100 pieces minimum.

**Dm** = It's possible to increase the hole, by boring, until Dm (enlarge).

Availability of stock in %

( ) 90% (●) 40% (●) 5% (●)

BOTECO® - © All right reserved - [www.boteco.it](http://www.boteco.it)  
Any unauthorized reproduction is strictly forbidden



**A - INDEXED AND FIXED LEVERS**