

LATCH SERIES

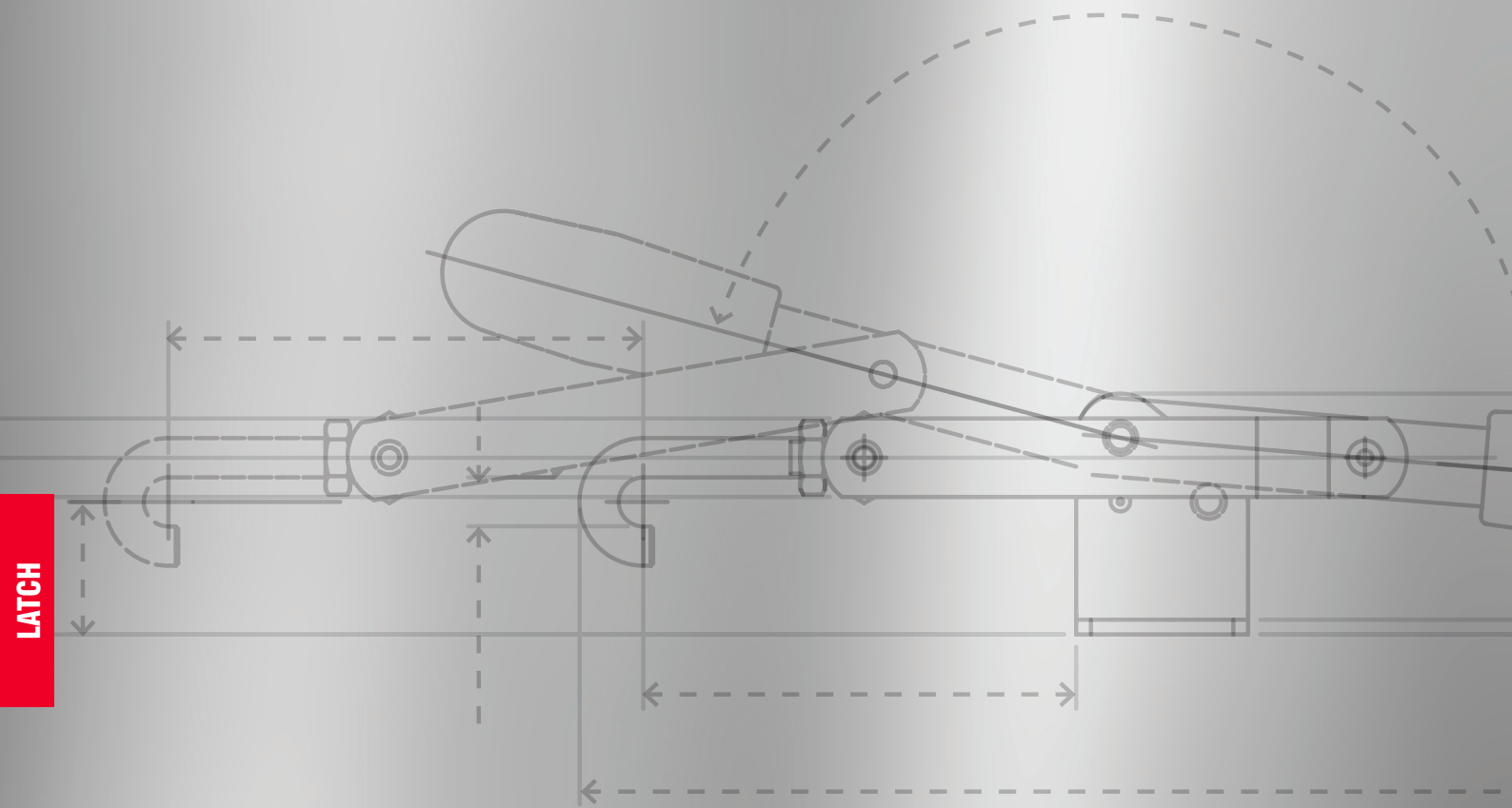

Here you can download
2D and 3D CAD drawings
of all products.



The tie rod clamping tools are characterized by a circular movement of the control lever that transforms into a linear movement of the tie rod. These products are mostly used in closing hinged lids, for container boxes or for machine and equipment doors.

LIGHT SERIES: It has holding forces from 160 to 1000 daN. They are available in galvanized steel and stainless steel.

HEAVY-DUTY SERIES: It has holding forces from 1700 to 4000 daN. They are available in hot-stamped, painted, phosphated or stainless steel.

HIGH TEMPERATURE SERIES:

It has retention forces of 1500 daN.

These tools are free of plastic parts and with the appropriate modifications compared to the light series models (couplings with different tolerances, changes in geometries, different finishes, etc., etc.) that make them suitable for use in environments that can reach 240-300 °C. The products are made of raw steel. They are normally used in the rotational moulding of plastic and require a type of clamping capable of working safely and quickly at high temperatures without uncertainties in closing and opening.

TOGGLE LATCHES: The ET-EG-ETL-EGL models represent a compact version of the lightweight series. They are normally used for closing lids or light doors. Thanks to the possibility of inserting a padlock, they can be used as anti-intrusion security locks.

TIE RODS: they can be single (eyebolt, T-shaped and hook-shaped) or double. All the tie rods are adjustable within the stroke (dimension D).

BASIC TYPES: The support base is parallel to the line of action of the force. In the closed position, the control lever is parallel to the support base. T - TF - TL - TFL - T2- T5 - T6.

The support base is perpendicular to the line of action of the force. In the closed position, the control lever is parallel to the support base. T3.

The support base is perpendicular to the line of action of the force. In the closed position, the control lever is perpendicular to the support base. T4.

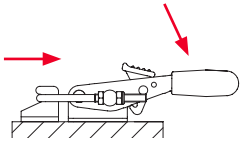

T6/T16 - T60/T160

DOUBLE TIE ROD TOGGLE CLAMPS, WITH SAFETY LEVER

Base, control lever, riveted pins, swinging pivot, hooking bracket, nuts and tie rod:

Galvanized steel (T6-T60) or **AISI 316 stainless steel** (T16-T160).

Safety lever:

Galvanized steel (T6-T60) or **AISI 316 stainless steel** (T16-T160), red polyurethane coating.

Handle:

Red polyurethane; resistant to oils, greases and other chemical agents.

Executions:

- **T6-16:** equipped with double threaded tie rod with nuts, swinging pivot and hooking bracket.
- **T60-T160:** equipped with swinging pivot and hooking bracket. Double tie rod to be ordered separately (see Accessories).

Features and applications:

These clamping tools are equipped with a special safety lever that ensures the perfect anchoring of the tool, preventing any accidental openings caused by vibrations or shocks. The tools of this series are particularly suitable for closing covers or doors of machines and equipment subjected to movement or vibration.

The position of the threaded tie rod can be adjusted within a certain range (see dimension "D") to fit the requirements of use.

The support base is parallel to the line of action of the force. In the closed position, the control lever is parallel to the support base.

A special grease is placed between the contacting surfaces during assembly.

Other available executions:

Heavy series.

Accessories:

- Tie rods of different sizes (see page 145).

T6

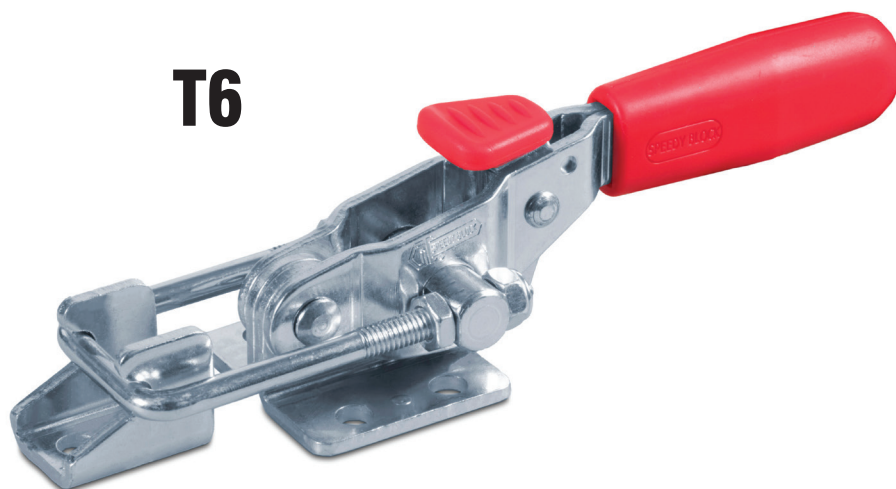

LATCH

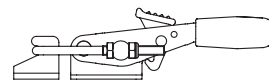
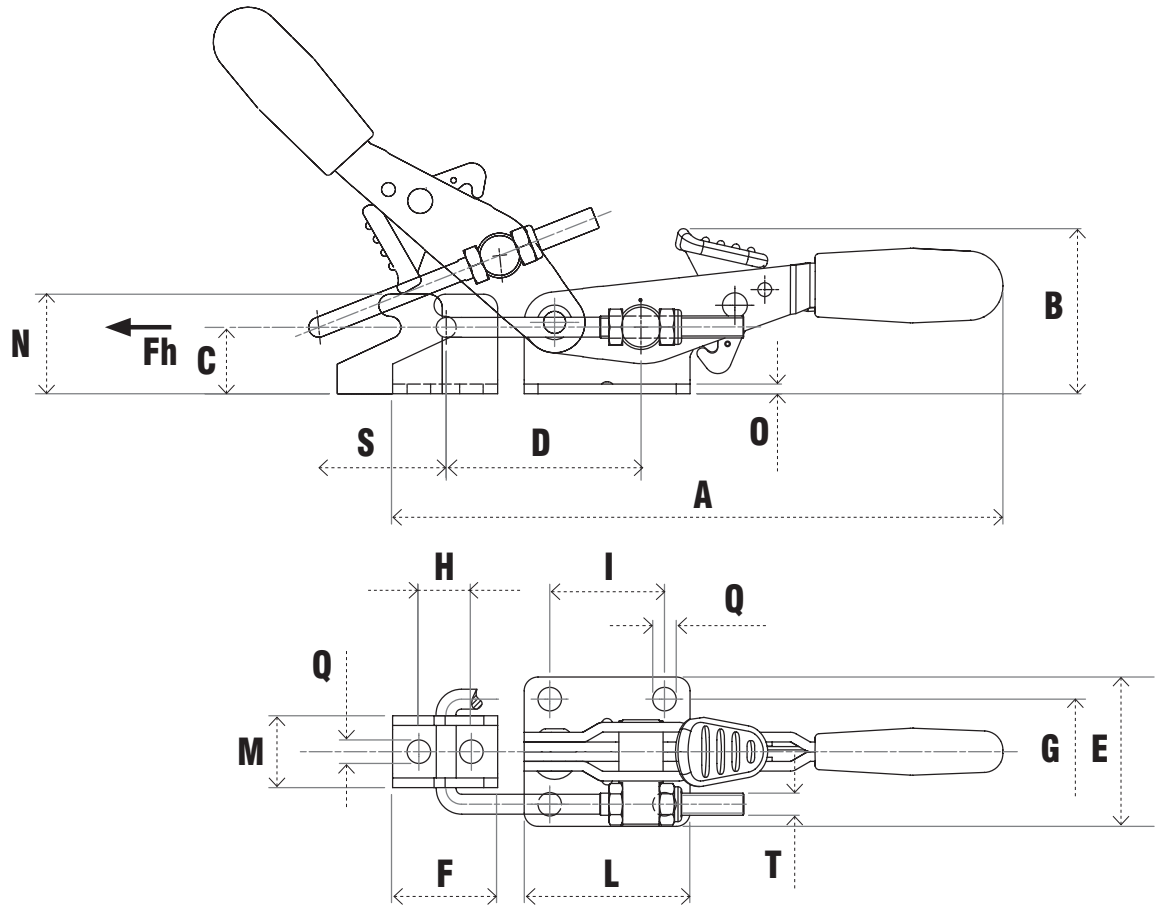

T6/T16

Tool provided with standard size tie rod.

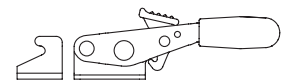

T60/T160

Tool supplied without tie rod. Match with tie rods of different sizes (see page 145).

Code	Description	A	B	C	D	E	F	G	H	I	L	M	N	O	Q	S	T	Fh (daN)	Gr. \triangle
AL780	160/T6	101	31	12	35÷44	28	20	19	10	16	26	14	18	2	4.3	18÷24	M4	160	95
AL785	320/T6	169	45	16	54÷63	44	28	32	14.3	19	40	22	25	3	6.5	26÷34	M6	320	331
AL790	700/T6	221	56	24	70÷90	54	38	38	19	41.5	60	26	36	3.5	8.5	40÷50	M8	750	644
AL820	160/T60		31	12		28	20	19	10	16	26	14	18	2	4.3		M4	160	76
AL822	320/T60		45	16		44	28	32	14.3	19	40	22	25	3	6.5		M6	320	258
AL824	700/T60		56	24		54	38	38	19	41.5	60	26	36	3.5	8.5		M8	750	507



Code	Description	A	B	C	D	E	F	G	H	I	L	M	N	O	Q	S	T	Fh (daN)	Gr. \triangle
AS600	160/T16	101	31	12	35÷44	28	20	19	10	16	26	14	18	2	4.3	18÷24	M4	160	95
AS605	320/T16	169	45	16	54÷63	44	28	32	14.3	19	40	22	25	3	6.5	26÷34	M6	320	331
AS610	700/T16	221	56	24	70÷90	54	38	38	19	41.5	60	26	36	3.5	8.5	40÷50	M8	750	644
AS640	160/T160		31	12		28	20	19	10	16	26	14	18	2	4.3		M4	160	78
AS642	320/T160		45	16		44	28	32	14.3	19	40	22	25	3	6.5		M6	320	260
AS644	700/T160		56	24		54	38	38	19	41.5	60	26	36	3.5	8.5		M8	750	507

