



MSBCCL SERIES

DC BRAKE MOTORS



VARIOUS CERTIFICATES



MOTOR SPARE PART LIST "EXPLODED DRAWING"

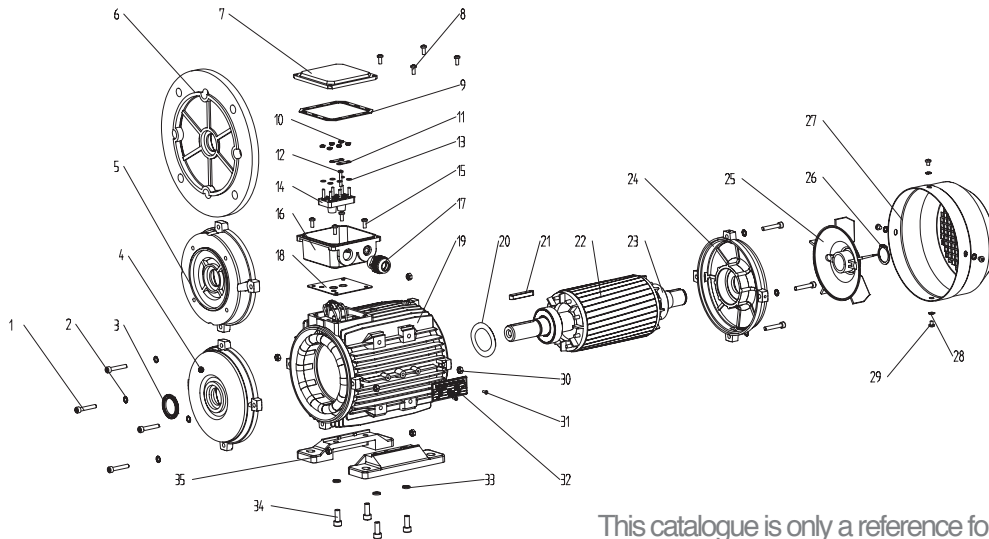













- | | |
|-------------------------------|-----------------------------|
| 1. Screw | 21. Key |
| 2. Gasket | 22. Rotor |
| 3. Oil seal | 23. Bearing |
| 4. Front endshield | 24. NDE endshield |
| 5. B14 flange | 25. Cooling fan |
| 6. B5 flange | 26. Fan circlip |
| 7. TB cover | 27. Fan cover |
| 8. TB fixing screws | 28. Fan cover fixing shim |
| 9. TB upper gasket | 29. Fan cover fixing screws |
| 10. Terminal board fixing nut | 30. Endshield fixing nut |
| 11. Terminal bridge | 31. Rivet |
| 12. Terminal pin | 32. Nameplate |
| 13. Terminal shim | 33. Foot fixing nut |
| 14. Terminal board | 34. Foot fixing screws |
| 15. TB fixing screws | 35. Foot |
| 16. TB base | |
| 17. Cable gland | |
| 18. TB bottom gasket | |
| 19. Frame | |
| 20. Preload washer | |

This catalogue is only a reference for users.
The concrete data be changed please contact with us before ordering.

MOUNTINGS AND POSITIONS

Mountings and positions for standard motors, according to IEC 60034-7, are defined by the codes mentioned in the following table.

	Standards			Frame Sizes
	CEI 2-14	IEC 60034-7		56-200
		Code I	Code II	
	B3	IM B3	IM 1001	Standard
	B3/B5	IM B35	IM 2001	Standard
	B5	IM B5	IM 3001	Standard
	B14	IM B14	IM 4001	Standard
	B8	IM B8	IM 1071	Upon request
	B6	IM B6	IM 1051	Upon request
	B7	IM B7	IM 1061	Upon request

	Standards			Frame Sizes
	CEI 2-14	IEC 60034-7		56-200
		Code I	Code II	
	V1	IM V1	IM 3011	Standard
	V3	IM V3	IM 3031	Upon request
	V5	IM V5	IM 1011	Upon request
	V6	IM V6	IM 1031	Upon request
	V1/V5	IM V15	IM 2011	Upon request

Aluminum Housing Electric Motors Bearings & Oil Seals

Frame	Bearings		Oil Seals	
	Drive End	Non-drive End	Drive End	Non-drive End
56	6201	6201	12×22×5	12×22×5
63	6201	6201	12×24×5	12×24×5
71	6202	6202	15×25×7	15×25×7
80	6204	6204	20×34×7	20×34×7
90S	6205	6205(6204)**	25×37×7	25×37×7(20×34×7)**
90L	6205	6205(6204)**	25×37×7	25×37×7(20×34×7)**
100L	6206	6206	30×44×7	30×44×7
112M	6306	6206(6306)	30×44×7	30×44×7
132S	6308	6208(6308)	40×58×7	40×58×7
132M/L	6308	6208(6308)	40×58×7	40×58×7
160M	6309	6309	45×65×8	45×65×8
160L	6309	6309	45×65×8	45×65×8
180M	6311	6211	55×72×8	55×72×8
180L	6311	6211	55×72×8	55×72×8
200L	6312	6212	60×80×8	60×80×8

SIMOTOP MSD/MSBCCL SERIES DIMENSIONAL DRAWINGS

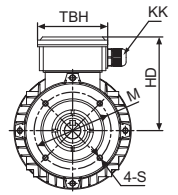
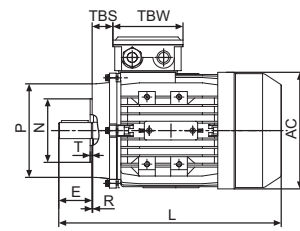
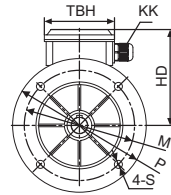
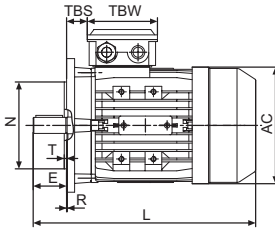
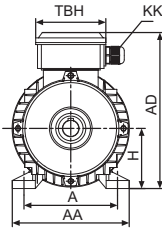
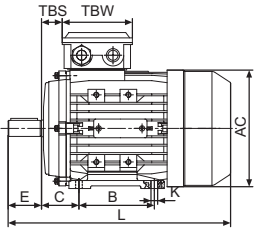

IM B3

IM B5

IM B14

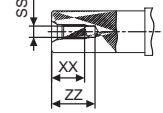
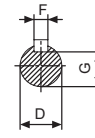
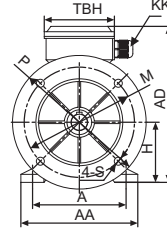
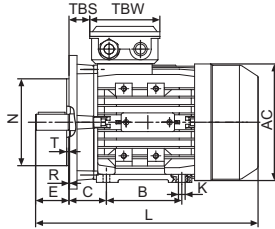
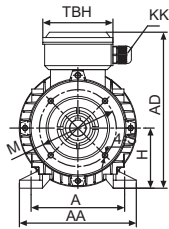
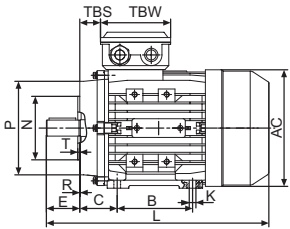

IM B34

IM B35

OVERALL & INSTALLATION DIMENSION

Frame	Foot Mounting					Shaft								General									
	H	A	B	C	K	D	E	F	G	SS	XX	ZZ	AA	AD	HD	AC	L	LCCL*	KK	TBS	TBW	TBH	
56	56	90	71	36	5.8X8.8	Ø9	20	3	7.2	M3	9	12	110	156	100	Ø117	196	232	1-M16X1.5	14	88	88	
63	63	100	80	40	7X10	Ø11	23	4	8.5	M4	10	14	120	171	108	Ø130	220	258	1-M16X1.5	14	94	94	
71**	71	112	90	45	7X10	Ø14	30	5	11	M5	12	17	132	186	115	Ø147	241(255)	282(296)	1-M20X1.5	20	94	94	
80	80	125	100	50	10X13	Ø19	40	6	15.5	M6	16	21	160	213	133	Ø163	290	339	1-M20X1.5	27	105	105	
90S	90	140	100	56	10X13	Ø24	50	8	20	M8	19	25	175	229	139	Ø183	312	361	1-M20X1.5	30	105	105	
90L1/L2	90	140	125	56	10X13	Ø24	50	8	20	M8	19	25	175	229	139	Ø183	337/367	386/416	1-M20X1.5	30	105	105	
100**	100	160	140	63	12X15	Ø28	60	8	24	M10	22	30	198	252	152	Ø205	369(387)	425(443)	2-M20X1.5	26	105	105	
112	112	190	140	70	12X15	Ø28	60	8	24	M10	22	30	220	279	167	Ø229	395	463	2-M25X1.5	32	112	112	
132S	132	216	140	89	12X15	Ø38	80	10	33	M12	28	37	252	318	186	Ø265	437	497	2-M25X1.5	38	112	112	
132M/L	132	216	178	89	12X15	Ø38	80	10	33	M12	28	37	252	318	186	Ø265	475/501	535/561	2-M25X1.5	38	112	112	
160M/L	160	254	210/254	108	15X19	Ø42	110	12	37	M16	36	45	290	384	224	Ø325	640	697	2-M32X1.5	64	143	143	
180M/L	180	279	241/279	121	15X25	Ø48	110	14	42.5	M16	36	45	340	440	260	Ø368	730		2-M32X1.5	73	190	190	
200L	200	318	305	133	19X29	Ø55	110	16	49	M20	42	53	390	460	260	Ø368	745		2-M40X1.5	85	190	190	

Frame	B5						B5R						B14						B14B						
	M	N	P	T	S	R	M	N	P	T	S	R	N	M	P	T	S	R	N	M	P	T	S	R	
56	Ø100	Ø80	Ø120	3.0	Ø7	0							Ø50	Ø65	Ø80	2.5	M5	0							
63	Ø115	Ø95	Ø140	3.0	Ø10	0							Ø60	Ø75	Ø90	2.5	M5	0	Ø80	Ø100	Ø120	3.0	M6	0	
71**	Ø130	Ø110	Ø160	3.5	Ø10	0	Ø115	Ø95	Ø140	3.5	Ø10	0	Ø70	Ø85	Ø105	2.5	M6	0	Ø95	Ø115	Ø140	3.0	M8	0	
80	Ø165	Ø130	Ø200	3.5	Ø12	0	Ø130	Ø110	Ø160	3.5	Ø10	0	Ø80	Ø100	Ø120	3.0	M6	0	Ø110	Ø130	Ø160	3.5	M8	0	
90S	Ø165	Ø130	Ø200	3.5	Ø12	0	Ø130	Ø110	Ø160	3.5	Ø10	0	Ø95	Ø115	Ø140	3.0	M8	0	Ø110	Ø130	Ø160	3.5	M8	0	
90L1/L2	Ø165	Ø130	Ø200	3.5	Ø12	0	Ø130	Ø110	Ø160	3.5	Ø10	0	Ø95	Ø115	Ø140	3.0	M8	0	Ø110	Ø130	Ø160	3.5	M8	0	
100**	Ø215	Ø180	Ø250	4.0	Ø15	0	Ø165	Ø130	Ø200	4.0	Ø12	0	Ø110	Ø130	Ø160	3.5	M8	0	Ø130	Ø165	Ø200	3.5	M10	0	
112	Ø215	Ø180	Ø250	4.0	Ø15	0	Ø165	Ø130	Ø200	4.0	Ø12	0	Ø110	Ø130	Ø160	3.5	M8	0	Ø130	Ø165	Ø200	3.5	M10	0	
132S	Ø265	Ø230	Ø300	4.0	Ø15	0	Ø215	Ø180	Ø250	4.0	Ø15	0	Ø130	Ø165	Ø200	4.0	M10	0	Ø180	Ø215	Ø250	4.0	M12	0	
132M/L	Ø265	Ø230	Ø300	4.0	Ø15	0	Ø215	Ø180	Ø250	4.0	Ø15	0	Ø130	Ø165	Ø200	4.0	M10	0	Ø180	Ø215	Ø250	4.0	M12	0	
160M/L	Ø300	Ø250	Ø350	5.0	Ø19	0							Ø180	Ø215	Ø250	4.0	M12	0							
180M/L	Ø300	Ø250	Ø350	5.0	Ø19	0																			
200L	Ø350	Ø300	Ø400	5.0	Ø19	0																			

* This data is provided for MSBCCL series Brake motors both with and without hand release lever.

** This frame size has two housing sizes, the rated output is for normal "L" size, and increased output is for the bigger "L" size (refer to the figures in the bracket "**")

MSBCCL SERIES

ASYNCHRONOUS THREE-PHASE BRAKE MOTORS
WITH SQUIRREL CAGE ROTOR • DIRECT CURRENT BRAKE

MSBCCL series-enclosed construction externally ventilated
sizes 63 ~ 160.

The brake-motors of the MSBCCL series result from coupling an asynchronous three-phase motor and an electromagnetic D.C. brake unit.

Due to their reliability and operating safety, as well as their quick braking time (connection & disconnection time = 5~80 milliseconds) they are suitable for a great variety of applications, such as:

- Braking of loads or torques on the driving shaft.
- Braking of rotating masses to reduce any lost-time.
- Braking operations to increase the set-up precision.
- Braking of machine parts, according to safety rules.

TECHNICAL DATA

2 poles - 3000 rpm - 50Hz

Brake motors have a $\pm 6\%$ tolerance on the supply voltage

Model	Power (KW)	Speed (r/min)	Eff. (%)	Power Factor (Cos Φ)	Current (A)			T _{st} /T _n (Times)	T _{max} /T _n (Times)	T _{min} /T _n (Times)	I _{st} /I _n (Times)	Noise dB(A)
					230V	400V	690V					
MSBCCL631-2	0.18	2710	63	0.75	0.95	0.55	0.32	2.2	2.4	1.6	6	61
MSBCCL632-2	0.25	2710	65	0.78	1.23	0.71	0.41	2.2	2.4	1.6	6	61
MSBCCL633-2	0.37	2710	65	0.78	1.82	1.05	0.61	2.2	2.4	1.6	6	62
MSBCCL711-2	0.37	2730	70	0.79	1.67	0.97	0.56	2.2	2.4	1.6	6	64
MSBCCL712-2	0.55	2760	71	0.79	2.45	1.42	0.82	2.2	2.4	1.6	6	64
MSBCCL713-2	0.75	2730	72	0.82	3.18	1.83	1.06	2.2	2.4	1.5	6	65
MSBCCL801-2	0.75	2770	73	0.84	3.06	1.77	1.02	2.2	2.4	1.5	6	67
MSBCCL802-2	1.1	2770	76.2	0.83	4.35	2.51	1.45	2.2	2.4	1.5	6	67
MSBCCL803-2	1.5	2800	78.5	0.83	5.87	3.32	1.92	2.2	2.4	1.5	6	70
MSBCCL90S-2	1.5	2840	78.5	0.84	5.76	3.28	1.90	2.2	2.4	1.5	6	72
MSBCCL90L1-2	2.2	2840	81	0.85	8.0	4.61	2.66	2.2	2.4	1.4	6	72
MSBCCL90L2-2	3	2840	82.6	0.86	10.56	6.10	3.52	2.2	2.4	1.4	6	74
MSBCCL100L1-2	3	2840	82.6	0.87	10.44	6.03	3.48	2.2	2.3	1.4	7	76
MSBCCL100L2-2	4	2850	84.2	0.87	13.65	7.88	4.55	2.2	2.3	1.4	7.5	77
MSBCCL112M-2	4	2880	84.2	0.87	13.65	7.88	4.55	2.2	2.3	1.4	7.5	77
MSBCCL112L-2	5.5	2880	85.7	0.88	18.23	10.53	6.08	2.2	2.3	1.2	7.5	78
MSBCCL132S1-2	5.5	2900	85.7	0.88	18.23	10.53	6.08	2	2.2	1.2	7.5	80
MSBCCL132S2-2	7.5	2920	87	0.88	24.49	14.14	8.16	2	2.2	1.2	7.5	80
MSBCCL132M1-2	9.2	2930	88	0.89	29.87	17.25	9.96	2	2.2	1.2	7.5	81
MSBCCL132M2-2	11	2930	88.4	0.9	34.57	19.96	11.52	2	2.2	1.2	7.5	83
MSBCCL160M1-2	11	2940	88.4	0.9	34.57	19.96	11.52	2	2.2	1.2	7.5	86
MSBCCL160M2-2	15	2940	89.4	0.91	46.09	26.61	15.36	2	2.2	1.2	7.5	86
MSBCCL160L-2	18.5	2940	90	0.91	56.47	32.6	18.82	2	2.2	1.1	7.5	86

Type	Brake Type K	Brake Torque Nm	Brake Rated Power W	J Brake Pd ² Kg ^m ²	No. of Starts/hr. Under No Load	Delayed Cut-in Time ★ Msec.	Quick Cut-in Time Msec.	Cut Out Time Msec.	Noise dB(A)
MSBCCL63	K 1	5	15	0.00005	3000	45	20	10	62
MSBCCL 71	K 2	12	20	0.00014	3000	50	30	15	64
MSBCCL 80	K 3	16	25	0.00021	1300	55	30	15	67
MSBCCL 90S	K 4	20	30	0.00039	1100	65	40	15	72
●MSBCCL 90S	K 4 D	40	30	0.00078	1100	65	40	15	72
MSBCCL 90 L	K 4	20	30	0.00039	1100	65	40	15	72
●MSBCCL 90 L	K 4 D	40	30	0.00078	1100	65	40	15	72
MSBCCL 100 L	K 5	40	45	0.00104	900	75	45	20	76
●MSBCCL 100 L	K 6	60	50	0.00135	900	180	85	25	76
MSBCCL 112 MT	K 5	40	45	0.00104	880	75	45	20	77
MSBCCL 112 M	K 6	60	50	0.00135	880	180	85	25	78
MSBCCL 132 S	K 7	90	55	0.00219	480	200	95	50	80
●MSBCCL 132 S	K 7 D	180	55	0.00438	480	200	95	50	80
MSBCCL 132 M	K 7	90	55	0.00219	450	200	95	50	80
●MSBCCL 132 M	K 7 D	180	55	0.00438	480	200	95	50	80
MSBCCL 160 MT	K 7 D	180	55	0.00438	350	200	95	50	86
MSBCCL 160 L	K 8	200	60	0.00408	350	210	100	60	86
●MSBCCL 160 L	K 8 D	400	60	0.00816	350	210	100	60	86

* Motor with increased braking torque on request

* On request, delayed brake cut in time for lifting equipments. We suggest double disk brake D for lifting equipments.

TECHNICAL DATA

4 poles - 1500 rpm - 50Hz

Brake motors have a $\pm 6\%$ tolerance on the supply voltage

Model	Power (KW)	Speed (r/min)	Eff. (%)	Power Factor (Cos Φ)	Current (A)			T _{st} /T _n (Times)	T _{max} /T _n (Times)	T _{min} /T _n (Times)	I _{st} /I _n (Times)	Noise dB(A)
					230V	400V	690V					
MSBCCL631-4	0.12	1350	57	0.64	0.82	0.47	0.27	2.2	2.4	1.7	6	52
MSBCCL632-4	0.18	1350	59	0.65	1.17	0.68	0.39	2.2	2.4	1.7	6	52
MSBCCL633-4	0.25	1350	60	0.66	1.58	0.91	0.53	2.2	2.4	1.7	6	54
MSBCCL711-4	0.25	1350	60	0.72	1.45	0.84	0.48	2.2	2.4	1.7	6	55
MSBCCL712-4	0.37	1370	65	0.74	1.92	1.11	0.64	2.2	2.4	1.7	6	55
MSBCCL713-4	0.55	1380	66	0.75	2.78	1.60	0.93	2.2	2.4	1.7	6	57
MSBCCL801-4	0.55	1370	67	0.75	2.74	1.58	0.91	2.2	2.4	1.7	6	58
MSBCCL802-4	0.75	1380	72	0.78	3.34	1.93	1.11	2.2	2.4	1.6	6	58
MSBCCL803-4	1.1	1390	76.2	0.78	4.63	2.67	1.54	2.2	2.4	1.6	6	60
MSBCCL90S-4	1.1	1400	76.2	0.79	4.57	2.64	1.52	2.2	2.4	1.6	6	61
MSBCCL90L-4	1.5	1400	78.5	0.8	5.97	3.45	1.99	2.2	2.4	1.6	6	61
MSBCCL90L2-4	2.2	1400	81	0.8	8.45	4.90	2.83	2.2	2.4	1.5	7	63
MSBCCL100L1-4	2.2	1420	81	0.81	8.38	4.84	2.79	2.2	2.3	1.5	7	64
MSBCCL100L2-4	3	1420	82.6	0.81	11.21	6.47	3.74	2.2	2.3	1.5	7	64
MSBCCL100L3-4	4	1430	84.2	0.82	14.18	8.36	4.83	2.2	2.3	1.5	7	65
MSBCCL112M-4	4	1430	84.2	0.83	14.31	8.26	4.77	2.2	2.2	1.5	7	65
MSBCCL112L-4	5.5	1440	85.7	0.83	19.33	11.16	6.44	2.2	2.2	1.4	7	68
MSBCCL132S-4	5.5	1450	85.7	0.84	19.1	11.03	6.37	2.2	2.2	1.4	7	71
MSBCCL132M-4	7.5	1450	87	0.85	25.35	14.64	8.45	2.2	2.2	1.4	7	71
MSBCCL132L1-4	9.2	1460	87.5	0.85	30.92	17.85	10.31	2.2	2.2	1.4	7.5	74
MSBCCL132L2-4	10	1460	88	0.85	33.42	19.3	11.14	2.2	2.2	1.4	7.5	74
MSBCCL132L2-4	11	1460	88.4	0.86	36.17	20.88	12.06	2.2	2.2	1.4	7.5	74
MSBCCL160M-4	11	1460	88.4	0.87	35.76	20.64	11.92	2.2	2.2	1.4	7	75
MSBCCL160L-4	15	1460	88.4	0.87	48.76	28.15	16.25	2.2	2.2	1.4	7.5	75

Type	Brake Type K	Brake Torque Nm	Brake Rated Power W	J Brake Pd ² Kgm ²	No. of Starts/hr. Under No Load	Delayed Cut-in Time ★ Msec.	Quick Cut-in Time Msec.	Cut Out Time Msec.	Noise dB(A)
MSBCCL63	K 1	5	15	0.00005	3000	45	20	10	52
MSBCCL 71	K 2	12	20	0.00014	3000	50	30	15	55
MSBCCL 80	K 3	16	25	0.00021	1300	55	30	15	58
MSBCCL 90S	K 4	20	30	0.00039	1100	65	40	15	61
●MSBCCL 90S	K 4 D	40	30	0.00078	1100	65	40	15	61
MSBCCL 90 L	K 4	20	30	0.00039	1100	65	40	15	63
●MSBCCL 90 L	K 4 D	40	30	0.00078	1100	65	40	15	63
MSBCCL 100 L	K 5	40	45	0.00104	900	75	45	20	64
●MSBCCL 100 L	K 6	60	50	0.00135	900	180	85	25	65
MSBCCL 112 MT	K 5	40	45	0.00104	880	75	45	20	65
MSBCCL 112 M	K 6	60	50	0.00135	880	180	85	25	65
MSBCCL 132 S	K 7	90	55	0.00219	480	200	95	50	71
●MSBCCL 132 S	K 7 D	180	55	0.00438	480	200	95	50	71
MSBCCL 132 M	K 7	90	55	0.00219	450	200	95	50	71
●MSBCCL 132 M	K 7 D	180	55	0.00438	480	200	95	50	71
MSBCCL 160 MT	K 7 D	180	55	0.00438	350	200	95	50	75
MSBCCL 160 L	K 8	200	60	0.00408	350	210	100	60	75
●MSBCCL 160 L	K 8 D	400	60	0.00816	350	210	100	60	75

* Motor with increased braking torque on request

* On request, delayed brake cut in time for lifting equipments. We suggest double disk brake D for lifting equipments.

TECHNICAL DATA

6 poles - 1000 rpm - 50Hz

Brake motors have a $\pm 6\%$ tolerance on the supply voltage

Model	Power (KW)	Speed (r/min)	Eff. (%)	Power Factor (Cos Φ)	Current (A)			T _{st} /T _n (Times)	T _{max} /T _n (Times)	T _{min} /T _n (Times)	I _{st} /I _n (Times)	Noise dB(A)
					230V	400V	690V					
MSBCCL631-6	0.09	840	42	0.61	0.88	0.51	0.29	2	2	1.5	3.5	50
MSBCCL632-6	0.12	850	45	0.62	1.08	0.62	0.36	2	2	1.5	3.5	50
MSBCCL711-6	0.18	880	56	0.66	1.22	0.70	0.41	1.6	1.7	1.5	4	52
MSBCCL712-6	0.25	900	59	0.7	1.51	0.87	0.50	2.1	2.2	1.5	4	52
MSBCCL713-6	0.37	890	61	0.69	2.2	1.27	0.73	2	2.1	1.5	4	54
MSBCCL801-6	0.37	900	62	0.7	2.13	1.23	0.71	1.9	1.9	1.5	4	56
MSBCCL802-6	0.55	900	67	0.72	2.85	1.65	0.95	2	2.3	1.5	4	56
MSBCCL803-6	0.75	900	68	0.72	3.83	2.21	1.28	2	2.3	1.5	4	58
MSBCCL90S-6	0.75	920	69	0.72	3.77	2.18	1.26	2.2	2.2	1.5	5.5	59
MSBCCL90L-6	1.1	925	72	0.73	5.23	3.02	1.74	2.2	2.2	1.3	5.5	59
MSBCCL100L-6	1.5	945	74	0.76	6.67	3.85	2.22	2.2	2.2	1.3	6	61
MSBCCL112M-6	2.2	955	78	0.76	9.28	5.36	3.09	2.2	2.2	1.3	6	64
MSBCCL132S-6	3	960	79	0.76	12.49	7.21	4.16	2	2	1.3	6.5	64
MSBCCL132M1-6	4	960	80.5	0.76	16.35	9.44	5.45	2	2	1.3	6.5	68
MSBCCL132M2-6	5.5	960	83	0.77	21.51	12.42	7.17	2	2	1.3	6.5	68
MSBCCL132L-6	7.5	960	85	0.77	28.65	16.54	9.55	2	2	1.3	6.5	68
MSBCCL160M-6	7.5	960	86	0.8	27.25	15.73	9.08	2	2.2	1.3	6.5	68
MSBCCL160L-6	11	960	87.5	0.79	39.78	22.97	13.26	2	2.2	1.2	6.5	73

Type	Brake Type K	Brake Torque Nm	Brake Rated Power W	J Brake Pd ² Kgm ²	No. of Starts/hr. Under No Load	Delayed Cut-in Time ★ Msec.	Quick Cut-in Time Msec.	Cut Out Time Msec.	Noise dB(A)
MSBCCL63	K 1	5	15	0.00005	3000	45	20	10	50
MSBCCL 71	K 2	12	20	0.00014	3000	50	30	15	52
MSBCCL 80	K 3	16	25	0.00021	1300	55	30	15	56
MSBCCL 90S	K 4	20	30	0.00039	1100	65	40	15	59
●MSBCCL 90S	K 4 D	40	30	0.00078	1100	65	40	15	59
MSBCCL 90 L	K 4	20	30	0.00039	1100	65	40	15	59
●MSBCCL 90 L	K 4 D	40	30	0.00078	1100	65	40	15	59
MSBCCL 100 L	K 5	40	45	0.00104	900	75	45	20	61
●MSBCCL 100 L	K 6	60	50	0.00135	900	180	85	25	61
MSBCCL 112 MT	K 5	40	45	0.00104	880	75	45	20	64
MSBCCL 112 M	K 6	60	50	0.00135	880	180	85	25	64
MSBCCL 132 S	K 7	90	55	0.00219	480	200	95	50	64
●MSBCCL 132 S	K 7 D	180	55	0.00438	480	200	95	50	64
MSBCCL 132 M	K 7	90	55	0.00219	450	200	95	50	68
●MSBCCL 132 M	K 7 D	180	55	0.00438	480	200	95	50	68
MSBCCL 160 MT	K 7 D	180	55	0.00438	350	200	95	50	68
MSBCCL 160 L	K 8	200	60	0.00408	350	210	100	60	73
●MSBCCL 160 L	K 8 D	400	60	0.00816	350	210	100	60	73

* Motor with increased braking torque on request

* On request, delayed brake cut in time for lifting equipments. We suggest double disk brake D for lifting equipments.

TECHNICAL DATA

8 poles - 750 rpm - 50Hz

Brake motors have a $\pm 6\%$ tolerance on the supply voltage

Model	Power (KW)	Speed (r/min)	Eff. (%)	Power Factor (Cos Φ)	Current (A)			T _{st} /T _n (Times)	T _{max} /T _n (Times)	T _{min} /T _n (Times)	I _{st} /I _n (Times)	Noise dB(A)
					230V	400V	690V					
MSBCCL631-6	0.09	840	42	0.61	0.88	0.51	0.29	2	2	1.5	3.5	50
MSBCCL632-6	0.12	850	45	0.62	1.08	0.62	0.36	2	2	1.5	3.5	50
MSBCCL711-6	0.18	880	56	0.66	1.22	0.70	0.41	1.6	1.7	1.5	4	52
MSBCCL712-6	0.25	900	59	0.7	1.51	0.87	0.50	2.1	2.2	1.5	4	52
MSBCCL713-6	0.37	890	61	0.69	2.2	1.27	0.73	2	2.1	1.5	4	54
MSBCCL801-6	0.37	900	62	0.7	2.13	1.23	0.71	1.9	1.9	1.5	4	56
MSBCCL802-6	0.55	900	67	0.72	2.85	1.65	0.95	2	2.3	1.5	4	56
MSBCCL803-6	0.75	900	68	0.72	3.83	2.21	1.28	2	2.3	1.5	4	58
MSBCCL90S-6	0.75	920	69	0.72	3.77	2.18	1.26	2.2	2.2	1.5	5.5	59
MSBCCL90L-6	1.1	925	72	0.73	5.23	3.02	1.74	2.2	2.2	1.3	5.5	59
MSBCCL100L-6	1.5	945	74	0.76	6.67	3.85	2.22	2.2	2.2	1.3	6	61
MSBCCL112M-6	2.2	955	78	0.76	9.28	5.36	3.09	2.2	2.2	1.3	6	64
MSBCCL132S-6	3	960	79	0.76	12.49	7.21	4.16	2	2	1.3	6.5	64
MSBCCL132M1-6	4	960	80.5	0.76	16.35	9.44	5.45	2	2	1.3	6.5	68
MSBCCL132M2-6	5.5	960	83	0.77	21.51	12.42	7.17	2	2	1.3	6.5	68
MSBCCL132L-6	7.5	960	85	0.77	28.65	16.54	9.55	2	2	1.3	6.5	68
MSBCCL160M-6	7.5	960	86	0.8	27.25	15.73	9.08	2	2.2	1.3	6.5	68
MSBCCL160L-6	11	960	87.5	0.79	39.78	22.97	13.26	2	2.2	1.2	6.5	73

Type	Brake Type K	Brake Torque Nm	Brake Rated Power W	J Brake Pd ² Kgm ²	No. of Starts/hr. Under No Load	Delayed Cut-in Time ★ Msec.	Quick Cut-in Time Msec.	Cut Out Time Msec.	Noise dB(A)
MSBCCL63	K 1	5	15	0.00005	3000	45	20	10	50
MSBCCL 71	K 2	12	20	0.00014	3000	50	30	15	52
MSBCCL 80	K 3	16	25	0.00021	1300	55	30	15	56
MSBCCL 90S	K 4	20	30	0.00039	1100	65	40	15	59
●MSBCCL 90S	K 4 D	40	30	0.00078	1100	65	40	15	59
MSBCCL 90 L	K 4	20	30	0.00039	1100	65	40	15	59
●MSBCCL 90 L	K 4 D	40	30	0.00078	1100	65	40	15	59
MSBCCL 100 L	K 5	40	45	0.00104	900	75	45	20	61
●MSBCCL 100 L	K 6	60	50	0.00135	900	180	85	25	61
MSBCCL 112 MT	K 5	40	45	0.00104	880	75	45	20	64
MSBCCL 112 M	K 6	60	50	0.00135	880	180	85	25	64
MSBCCL 132 S	K 7	90	55	0.00219	480	200	95	50	64
●MSBCCL 132 S	K 7 D	180	55	0.00438	480	200	95	50	64
MSBCCL 132 M	K 7	90	55	0.00219	450	200	95	50	68
●MSBCCL 132 M	K 7 D	180	55	0.00438	480	200	95	50	68
MSBCCL 160 MT	K 7 D	180	55	0.00438	350	200	95	50	68
MSBCCL 160 L	K 8	200	60	0.00408	350	210	100	60	73
●MSBCCL 160 L	K 8 D	400	60	0.00816	350	210	100	60	73

* Motor with increased braking torque on request

* On request, delayed brake cut in time for lifting equipments. We suggest double disk brake D for lifting equipments.

MSBCCL SERIES BRAKE MOTORS

OPERATING PRINCIPLE

The direct current brake is fed by means of an electronic circuit with diode bridge (rectifier) situated inside the terminal-box. When feeding the electromagnet (5), the movable anchor (4) is attracted towards the same, thus loading the braking torque springs (9) and allowing the disk (2), equipped with friction packing and fitted on the groove hub (6) to turn solitary the motor shaft (1) by means of a lye (7). By interrupting the feeding, the movable anchor (4), pushed by the braking torque springs (9), exerts a pressure upon the friction surface of the disk (2), thus causing its stopping.

ADJUSTMENT OF THE AIR GAP

The air gap (11) is the distance between the electromagnet (5) and the movable anchor (9).

The air gap has to be regularly checked, since due to the wear of the friction packing (2) it tends to increase.

Act on the brake adjusters (3) after having unloosen the screws (8) to bring the air gap to the required value.

Act on the ring nut (10) which acts on the braking torque springs (9) to adjust the braking torque.

Pls. contact our technical department for information on the air gap adjustment values.

HAND RELEASE WITH LEVER

Upon request a hand release with lever can be supplied.

In case of a current cutoff, acting on the lever (12), the release, connected to the movable anchor (4) overcomes the springs pressure, thus detaching the movable anchor from the disc friction packing (2) allowing the shaft to turn.

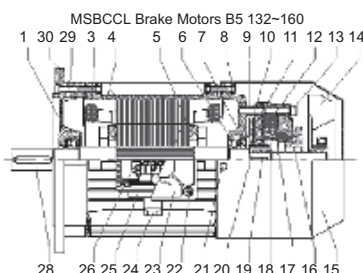
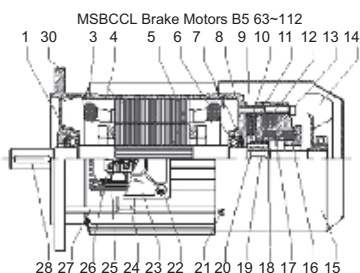
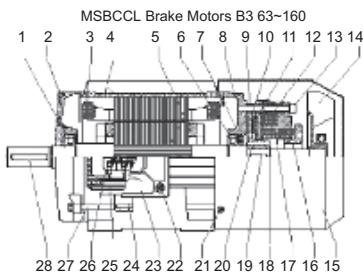
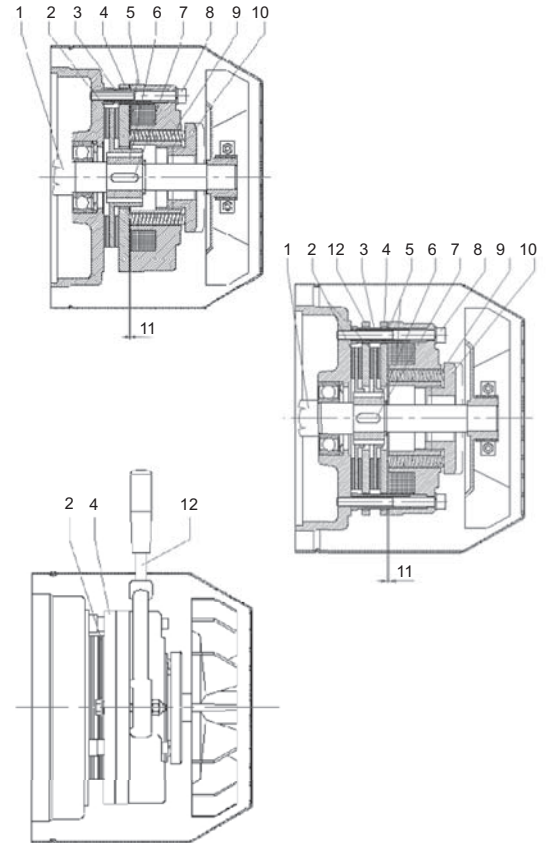

- | | |
|-----------------------------------|----------------------------------|
| 1. Front bearing | 16. Ring nut |
| 2. Front shield | 17. Spring |
| 3. Winding | 18. See gearing |
| 4. Frame with stator package | 19. Key brake side |
| 5. Shaft with rotor | 20. Toothed pinion |
| 6. Rear bearing | 21. Fixing screw for fan hood |
| 7. Spring | 22. Fixing crew for terminal-box |
| 8. Rear shield | 23. Terminal-box |
| 9. Adjusting bush | 24. Able-holder |
| 10. Brake disc | 25. Packing |
| 11. Moving anchor | 26. Terminal-block |
| 12. Electromagnet coil with diode | 27. Tie.bolt |
| 13. Fixing screws for brake | 28. Coupling side key |
| 14. Cooling fan | 29. Fixing screw for shield |
| 15. Fan hood | 30. Flange shield |

The technical characteristics, dimensions and other data in this catalog are not binding.

Simo Top Group reserves the right to change at any time and without notice.

www.simotopgroup.com



SIMOTOP GROUP SPA
Via Ca' Bianca 320
40024 Castel San Pietro (BO) - Italy
Tel. +39 051 6951975
Fax +39 051 941634
info@simotopgroup.com