

双节距传动链
Double pitch transmission chains

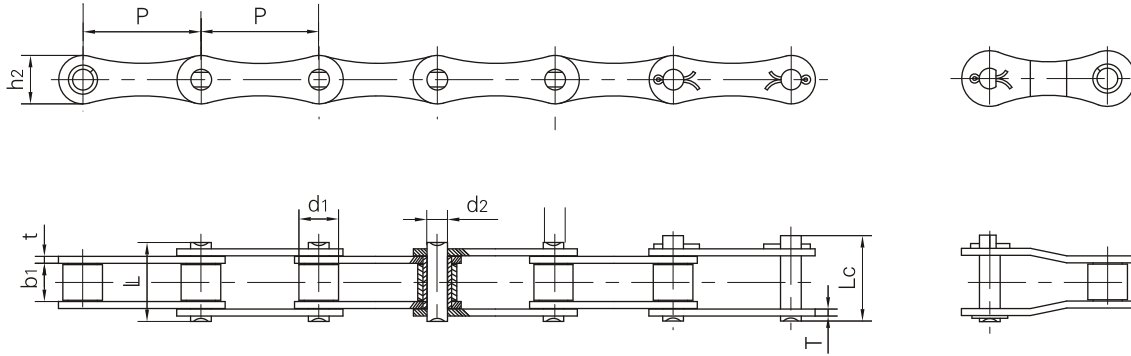

DIN/ISO 链号	ANSI 链号	节距 Pitch	滚子直径 Roller diameter	内节内宽 Width between inner plates	销轴直径 Pin diameter	销轴长度 Pin length		内链板高度 Inner plate depth	链板厚度 Plate thick- ness	极限拉伸载荷 Ultimate tensile strength	平均拉伸载荷 Average tensile strength	每米长重 Weight per meter
						L max	Lc max					
DIN/ISO Chain No.	ANSI Chain No.	P	d1 max	b1 min	d2 max	L max	Lc max	h2 max	t/T max	Q min	Q0	q
		mm	mm	mm	mm	mm	mm	mm	mm	kN/LB	kN	kg/m
208A	2040	25.40	7.95	7.85	3.96	16.6	17.8	12.0	1.50	14.1/3205	16.7	0.42
208B		25.40	8.51	7.75	4.45	16.7	18.2	11.8	1.60	18.0/4091	19.4	0.45
210A	2050	31.75	10.16	9.40	5.08	20.7	22.2	15.0	2.03	22.2/5045	28.1	0.73
210B		31.75	10.16	9.65	5.08	19.5	20.9	14.7	1.70	22.4/5091	27.5	0.65
212A	2060	38.10	11.91	12.57	5.94	25.9	27.7	18.0	2.42	31.8/7227	36.8	1.02
212B		38.10	12.07	11.68	5.72	22.5	25.2	16.0	1.85	29.0/6591	32.2	0.76
216A	2080	50.80	15.88	15.75	7.92	32.7	36.5	24.0	3.25	56.7/12886	65.7	1.70
216AH	2080H	50.80	15.88	15.75	7.92	36.2	39.4	24.0	4.00	56.7/12886	70.0	2.17
216B		50.80	15.88	17.02	8.28	36.1	39.1	21.0	4.15/3.1	60.0/13636	72.8	1.75
220A	2100	63.50	19.05	18.90	9.53	40.4	44.7	30.0	4.00	88.5/20114	102.6	2.55
220B		63.50	19.05	19.56	10.19	41.3	45.0	26.4	4.5/3.5	95.0/14773	106.7	2.62
224A	2120	76.20	22.23	25.22	11.10	50.3	54.3	35.7	4.80	127.0/28864	147.3	4.06
224B		76.20	25.40	25.40	14.63	53.4	57.8	33.2	6.0/4.8	160.0/36364	178.0	4.70
228B		88.90	27.94	30.99	15.90	65.1	69.5	36.7	7.5/6.0	200.0/45455	222.0	6.23
232B		101.60	29.21	30.99	17.81	66.0	71.0	42.0	7.0/6.0	250.0/56818	277.5	6.72